

ITEM NO.	PART NUMBER	DESCRIPTION	QTY.
1	H2000W102	Inside Frame	1
2	H2000W103	Outside frame	1
4	H2000W105	Fork Pin	2
5	H2000W107	Chain Pin	1
6	H2000A101	Fork	2
7	H2000W111	Stand	2
10	H2500A101	Carriage Assembly	1
13	H2000M109	Carriage Roller	16
14	H2000M107	Top Roller Bushing	1 for single chain 2 for double chain
15	H2000M105	Top Roller	1 for single chain 2 for double chain

DO NOT SCALE DRAWING	MATERIAL:	FINISH:	PART NO.	REV	REV DATE: 6/29/2018
UNLESS OTHERWISE SPECIFIED DIMENSIONS ARE IN INCHES	WEIGHT LBS:	SCALE: 1:48		A	AUTHOR:
Sheet Name: Sheet1	PROJECT:	SHEET 1 OF 2	TITLE:		

Streamside Industries
4181 Boomer Line
St Clements, ON N0B 2M0

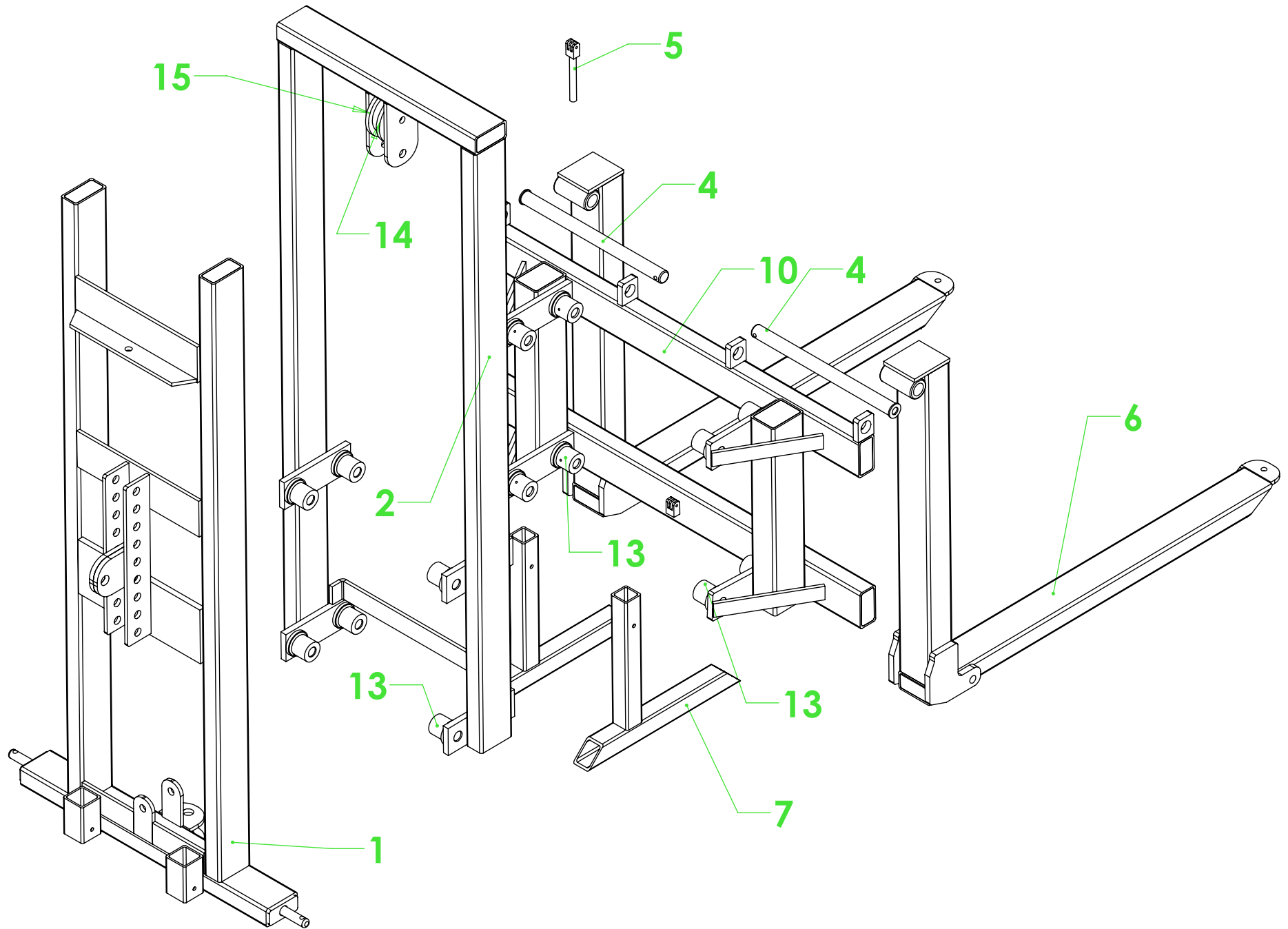

DO NOT SCALE DRAWING	MATERIAL:	FINISH:	PART NO.	REV	REV DATE: 6/29/2018
UNLESS OTHERWISE SPECIFIED DIMENSIONS ARE IN INCHES	WEIGHT LBS:	SCALE: 1:48		A	AUTHOR:
Sheet Name: Sheet2	PROJECT:	SHEET 2 OF 2	TITLE:		

Streamside Industries
 4181 Boomer Line
 St Clements, ON NOB 2M0