



Wifo Farm Equipment Ltd.

4181 Boomer Line
St Clements Ont., N0B 2M0
Phone 519-699-5658
Fax 519-699-5655
E-mail: sales@wifo.ca
www.wifo.ca

OPERATORS MANUAL

Single Auger Pull Type PTO Snow Blower

Models:

WBPT46, WBPT54, WBPT60, WBPT68, WBPT72, WBPT78, WBPT84,
WBPT96 and WBPT102

Congratulations on the purchase of your WIFO Snow Blower, you will enjoy years of trouble free operation with the simple maintenance steps in this manual, if you have any questions, please contact us.

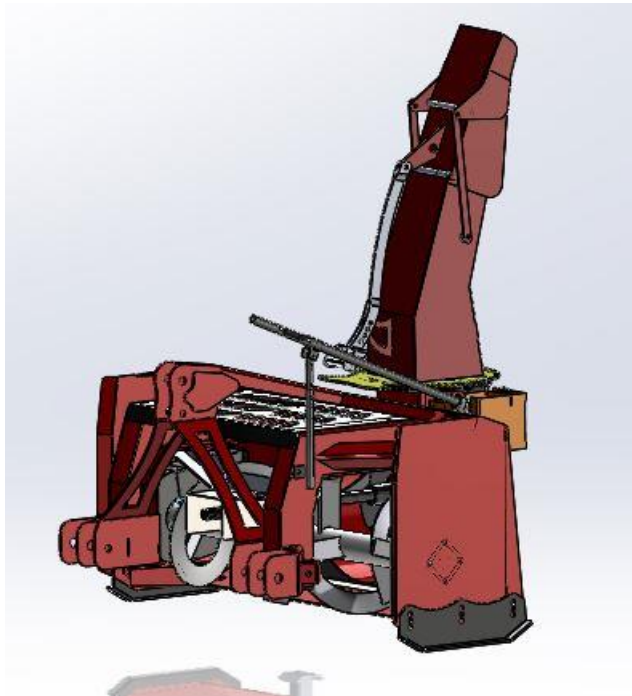

SAFETY PRECAUTIONS

1. Be sure all exposed moving parts such as shafts and adapters are properly guarded and that all coupling devices are securely attached before applying power. Do not use unless all shields are in place.
2. Do not wear loose fitting clothing in the vicinity of any moving parts.
3. Do not exceed recommended ground speed, recommended PTO speed, or recommended horsepower for the unit which you are using.
4. Keep all persons, pets, and livestock away from unit when in use.
5. Do not turn discharge chute towards persons, pets, livestock, or buildings when blower is in operation.
6. Before working on, servicing, or making adjustments to equipment, disengage power, lower unit to ground level, shut off engine, make sure all moving parts have stopped and all pressure in the hydraulic system is relieved.
7. Do not attempt to remove any obstruction from discharge chute until PTO is disengaged and engine is shut off.
8. Do not stand on auger to service any part of blower, as auger may turn causing either, a serious fall; or, the blower fan to rotate, presenting a danger to fingers, hands, or arms in the chute assembly or blower housing.
9. Keep hands and arms away from cables and turner bar of hydraulic hood turner until engine is shut off.
10. Always look to the rear before backing up.
11. Be aware of the presence of people and objects that may be obscured from vision by blowing or drifted snow. Be certain that no children have tunneled into snowbanks which are to be removed. Never let children slide down snowbanks in the vicinity of an operating blower.

ASSEMBLY AND SETUP OF BLOWERS:

1. The snowblower hood needs to be mounted on the blower frame, see image below:
2. Check oil level in gearbox.
3. Check all bolts for tightness.
4. Check auger drive chain tension and alignment. Adjust if necessary.
5. Grease PTO universal joints, shield retaining collars, and inner tube of PTO.

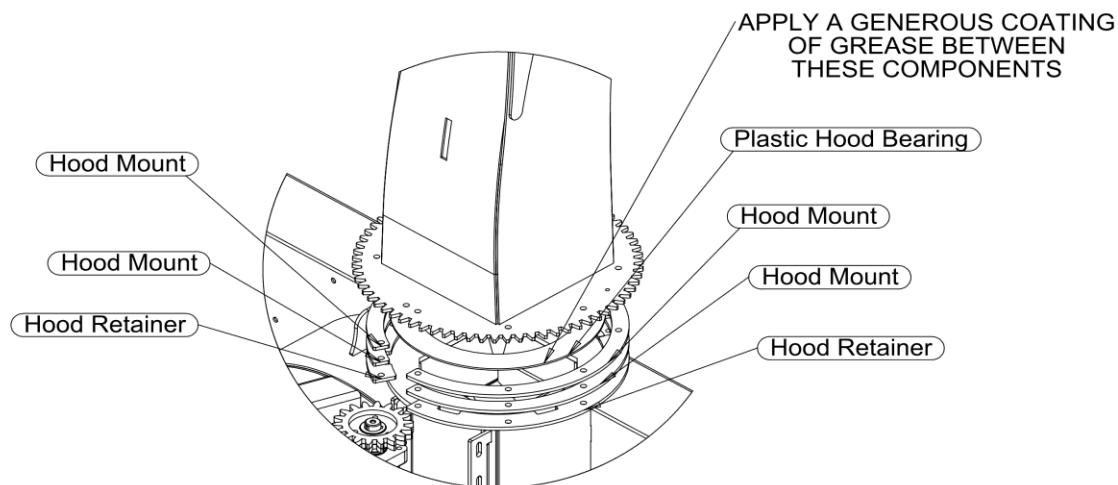

OPERATION

1. When attaching the blower make certain all guards are in place.
2. Ensure that the fan and auger rotate freely before connecting PTO shaft to the tractor.
3. Use proper pins and ensure that all connections are secure.
4. Engage the PTO at low engine RPM and slowly increase speed to operating level. Operating speed will vary with snow, weather, and ground conditions.
5. Adjust the top link of the three-point hitch to match the ground and snow conditions. Increasing the length will cause the blower to cut deeper into compacted snow, but may also cause the blower to scrape gravel or stones into the fan, which can be a danger to nearby persons, pets, livestock or buildings. Decreasing the length of the top link causes the blower to ride back on the skid shoes, raising the cutting height, thereby reducing the possibility of scraping gravel or stones into the blower.
6. Adjust the deflector for the distance of throw required. Moving the adjusting bar, to shorten the distance between the pins increases the distance thrown.
7. Be aware of the presence of people and objects that may be obscured from vision by blowing or drifted snow. Be certain that no children have tunneled into snowbanks which are to be removed. Never let children slide down snowbank in the vicinity of an operating blower.
- 8. Never run the blower faster than 540 RPM**

SERVICE

1. Before servicing or adjusting, disengage the PTO, lower the unit to the ground, and shut off engine.
2. To prevent freezing of hood or other moving parts apply a solution of antifreeze or light oil.
3. Check gearbox oil level on a regular basis. If oil level is low, use a good quality 80W-90 gear oil. Change oil after 50 hours during break-in period. Change after 700-750 hours or yearly.
4. Grease the shear assembly and hydraulic hood turner every five hours of operation.
5. Grease the auger bearings every ten hours of operation.
6. Check auger drive chain tension and alignment. Adjust if necessary.

Lubrication points include:

Auger bearings, drive bearings, hood turner grease fittings, drive bearing and chain. There is a shear pin is located under the drive shield which is easily replaceable with minimal tools.

Shear Bolt Specs for Snow Blowers

PTO Shaft	Bolt Size	QTY	Models
T20	M6x40MM Grade 8.8	1	WBPT46
T40	M8x50MM Grade 8.8	1	WBPT54, WBPT60, WBPT68
T50	M10x55MM Grade 8.8	1	WBPT72, WBPT78, WBPT84
T60	M10x60MM Grade 8.8	1	WBPT96, WBPT102

Shear Bolt Sprockets

50H Chain Sprocket	1/4-20 x 1.25" GRD 5	1	WBPT46
60H Chain	1/4-NC x 1.25" GRD 5	1	WBPT54 up to WBPT84
80H	1/4-NC x 1.25" GRD 5	2	WBPT96, WBPT102,

Shear Bolt Locator

Each Blower Is equipped with 2 shear pins 1 is located on the PTO shaft where it attached the shaft on the blower

The Second shear pin is located by the blue arrow on the picture bellow it is under the guard if your standing behind the blower facing the tractor it is on the RH side of the blower.

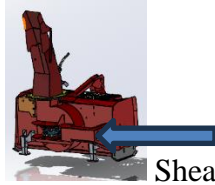

Shear pin Location Behind the guard

Spare parts list:

For complete Part list please visit the website
at

<http://www.wifo.ca/manuals.html>

Gear box T27D

Sleeve adapter, 1-1/4 X 1-1/4-19th spline Sprocket

60A38 60A38 x 1-1/2 w/ 4 bolt pattern Sprocket

80A30 80A30 x 1-1/2 w/ 4 bolt pattern Sprocket

100A24 80A30 x 1-1/2 w/ 4 bolt pattern Sprocket

60A15H Idler 60A15H X 5/8

Sprocket 80A11H Idler 80A11H x 3/4

Sprocket 100A09H Idler 100A09H

60B12H Shear bolt 60B12H-1-1/4

80B12H Shear bolt 80B12H x 1-3/4

HCFS207 Flange HCFS207-20-G FK

Chain 60H 60H PLI x 50' reel. heavy roller chain

60H-C/L 60 heavy roller chain connector link 60H-

O/L 60 Heavyroller chain off set link

80H Chain Chain 80H PLI X 50' reel heavy roller chain

80H-C/L 80 Heavy roller chain connectorlink

80H-O/L 80 heavy roller chain off setlink

100H Chain Chain 100H PLI X 10' Heavy roller chain 100H

C/L 100 Heavy roller chain connectorlink

100H O/L 100 Heavyroller chain off set link

Hood turn Motor

The hydraulic chute hood turn motor has a cushion valve installed for the relive if you need more pressure on the motor there are 2 pressure screws at the bottom of each port turn these clock wise for more pressure and counter clock wise for less pressure.

Turn Set screws clock wise for more Pressure
counter clockwise for less pressure

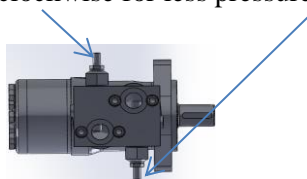

Maintenance

Each Blower has two bearings on each side of the auger these should be greased annually with **2 pumps each** or beginning of each season. Each blower is also equipped with a roller chain it goes from the shear bolt sprocket to the auger on the same side as the shear bolt. This should also be oiled with any type of oil annually or begin of each season. Roller Chain should be tightened annually as well the chain should have ¼” to ½” slack

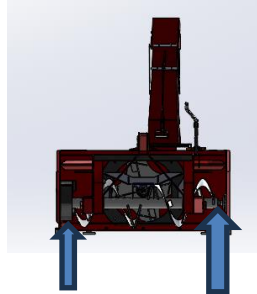

Bearing locations

WARRANTY

Warranty is at the sole discretion of the manufacturer. Your Wifo Snow Blower has a **2** year warranty from the date of purchase to the original owner. It is limited to Material and/or construction failures that have to be examined by the factory. So, if within one year from the date of purchase your Snow Blower fails due to a defect in material or workmanship, you will have to return it prepaid to the factory for inspection. The warranty does not apply to damage received during transport.

And as our policy is one of continuous improvement, we reserve the right to change specifications and prices or modify design, without notice or obligation.